

7/24/2026

FRIDAY

PATTERNS

LITTLE RIVER CIRCUIT

AQHA & STOCKHORSE

Classes

Senator Bob Martin Ag

Center

Williamston, NC

FRIDAY

AQHA W/T
STOCK HORSE
W/T

WT Trail 7-24-2026

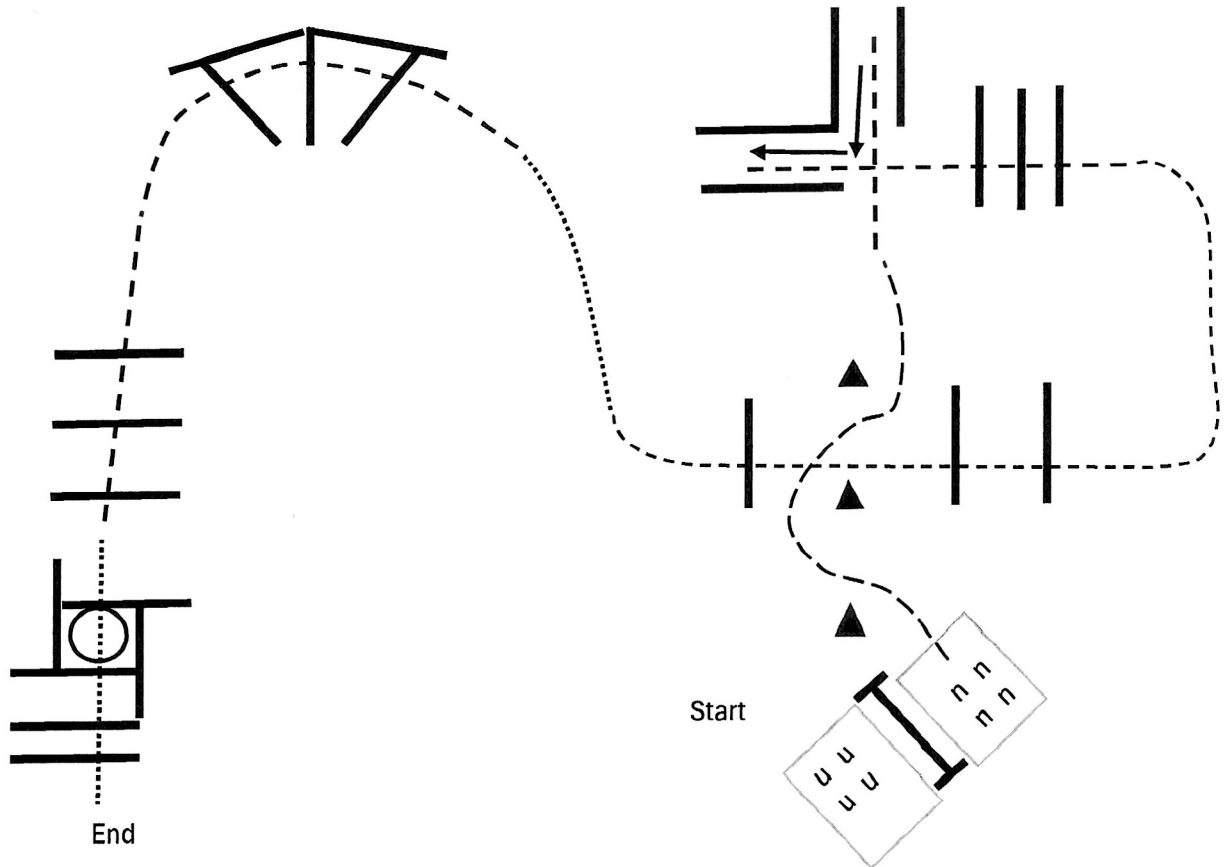

1. Left Hand Gate
2. Jog Serpentine into Chute
3. Back Chute
4. Jog Poles
5. Jog Poles
6. Walk
7. Jog Poles
8. Jog Poles
9. Walk into Box 360 Right
10. Walk Poles

STOCKHORSE W/T/L

L-1 GREEN

FRIDAY

Trail 7-24-2026

L-1 NOVICE

ROOKIE

YOUTH

AMATEUR

OPEN

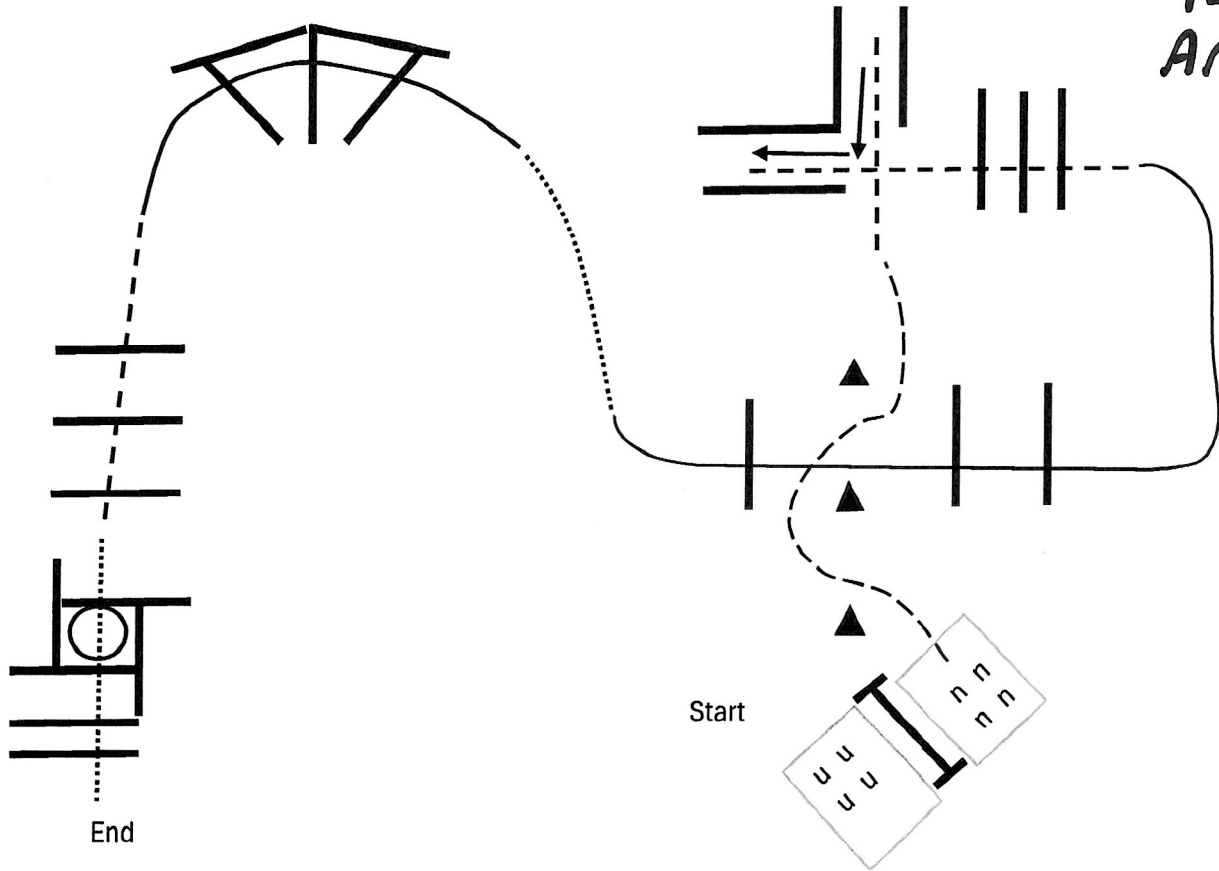

1. Left Hand Gate
2. Jog Serpentine into Chute
3. Back Chute
4. Jog Poles
5. Lope Poles RL
6. Walk
7. Lope Poles LL
8. Jog Poles
9. Walk into Box 360 Right
10. Walk Poles

FRIDAY

Horse Show Patterns AQHA

Western Horsemanship (Walk Trot) STOCKHORSE

Show Date:

† SMALL-FRY

www.HorseShowPatterns.com

www.HorseShowPatterns.com

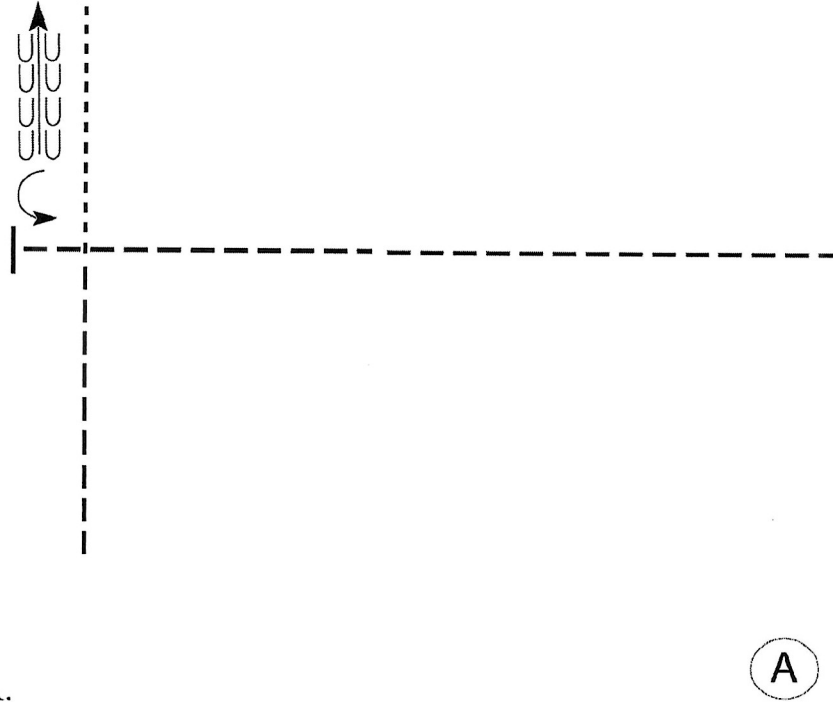

Be ready at A.

1. Perform a jog from A and a square corner toward center of pattern.
2. Continue the jog in a straight line.
3. Stop and perform a 1/4 turn to the left.
4. Back 5 steps.
5. Walk until you cross your line.
6. Exit arena at a jog.

Walk	-----
Jog	- - - - -
Extended Jog	— — — —
Lope	—————
Lead Change	
Back	
Marker	(B)

[WH/WT-104]

Pattern Provided by:

Judges

FRIDAY

Horse Show Patterns

W/I/L

Western Horsemanship (All Novice) + ROOKIE

Show Date:

STOCKHORSE

www.HorseShowPatterns.com

www.HorseShowPatterns.com

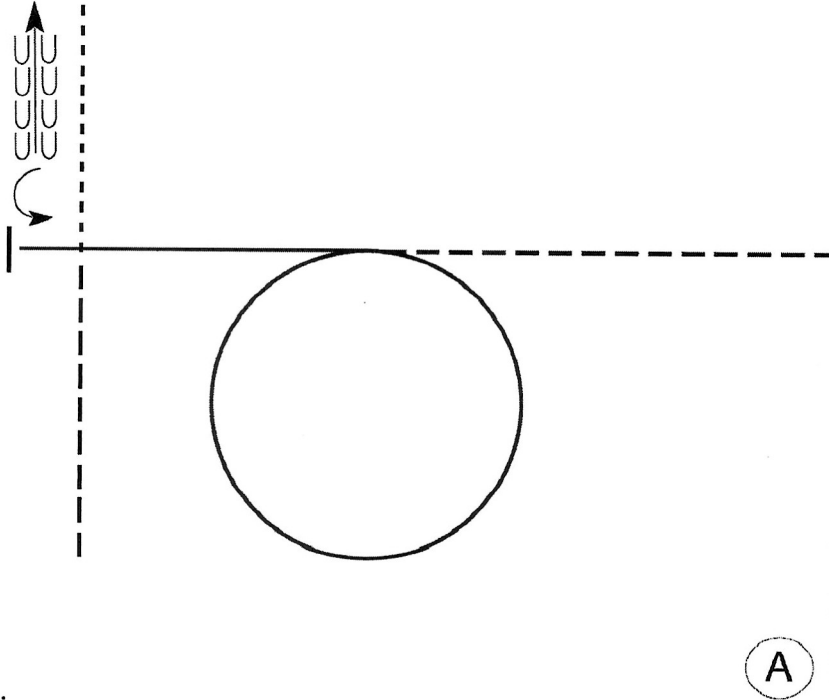

Be ready at A.

1. Perform a jog from A and a square corner toward center of pattern.
2. Lope a left lead circle.
3. Close the circle and continue loping on the left lead in a straight line.
4. Stop and perform a 1/4 turn to the left.
5. Back 5 steps.
6. Walk until you cross your line.
7. Exit arena at a jog.

Walk
Jog	-----
Extended Jog	-----
Lope	—————
Lead Change	
Back	
Marker	(B)

[WH/1-104]

Pattern Provided by:

Judges

Horse Show Patterns

FRIDAY

Western Horsemanship (Youth / Amateur)

Show Date:

SELECT

www.HorseShowPatterns.com

www.HorseShowPatterns.com

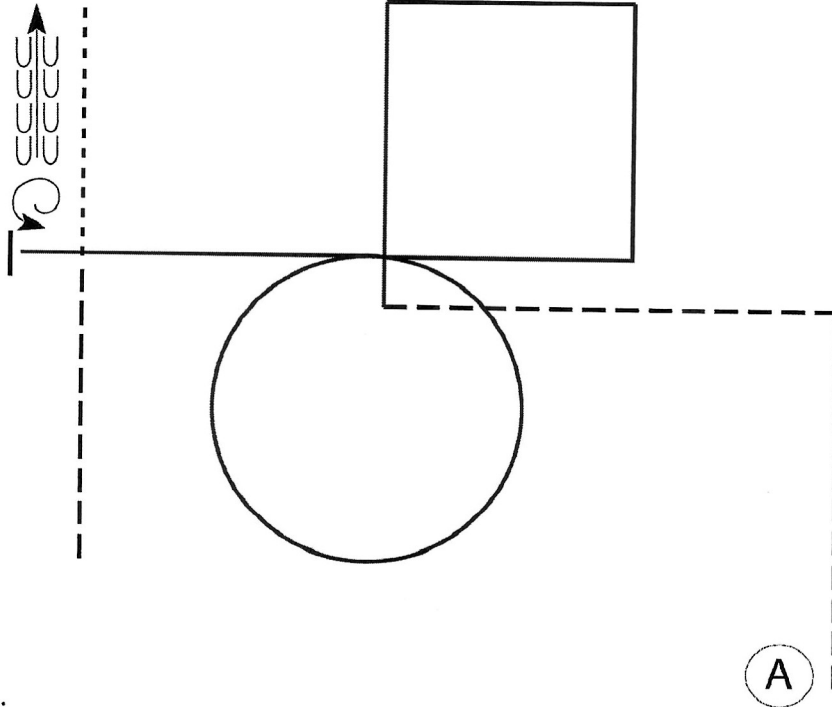

Be ready at A.

1. Perform a jog from A and a square corner toward center of pattern.
2. Make a square corner right at center.
3. Lope a right lead square.
4. Change leads at center and lope a left lead circle.
5. Close the circle and continue loping on the left lead in a straight line.
6. Stop and perform a 1 1/4 turn to the left.
7. Back 5 steps.
8. Walk until you cross your line.
9. Exit arena at a jog.

Walk	-----
Jog	- - - - -
Extended Jog	— — — —
Lope	—————
Lead Change	
Back	
Marker	Ⓚ

[WH/2-104]

Pattern Provided by:

Judges

LEVEL 1 WESTERN RIDING PATTERN 6

FRIDAY

LEGEND	
.....	Walk
- - -	Jog
————	Lope
//////	Back
————	Lead Changing Area

L-1 GREEN
 L-1 NOVICE
 AMATEUR
 L-1 NOVICE
 YOUTH

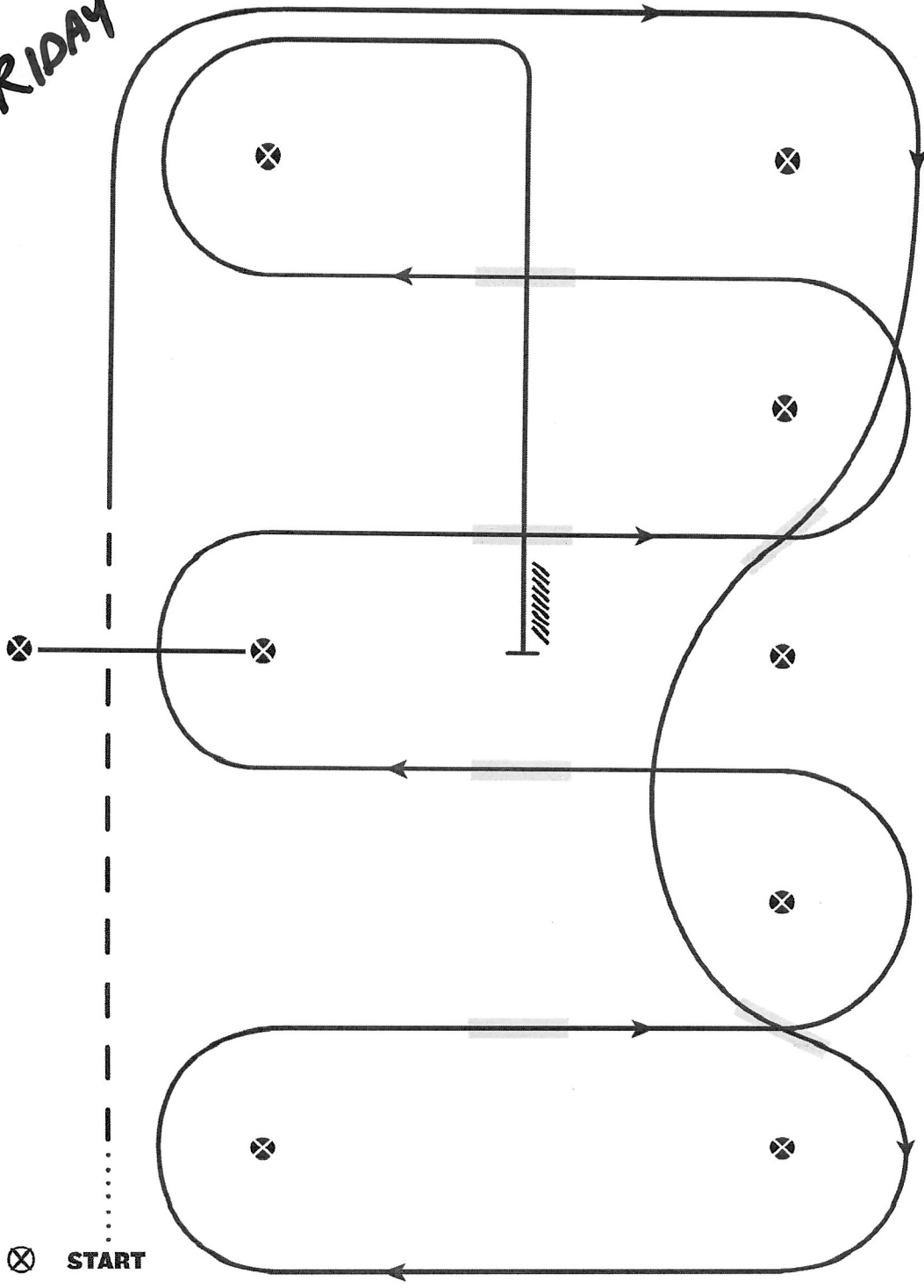

1. Walk at least 15 feet from start cone to the first marker, transition to jog, jog over log.
2. Transition to the lope right lead & lope around end
3. First line change
4. Second line change, lope around the end of arena
5. First crossing change
6. Second crossing change
7. Lope over log
8. Third crossing change
9. Fourth crossing change
10. Lope up the center, stop & back

WESTERN RIDING - PATTERN 6

FRIDAY

LEGEND

.....	Walk
- - -	Jog
————	Lope
///////	Back
————	Lead Changing Area

YOUTH
AMATEUR
JUNIOR
SENIOR

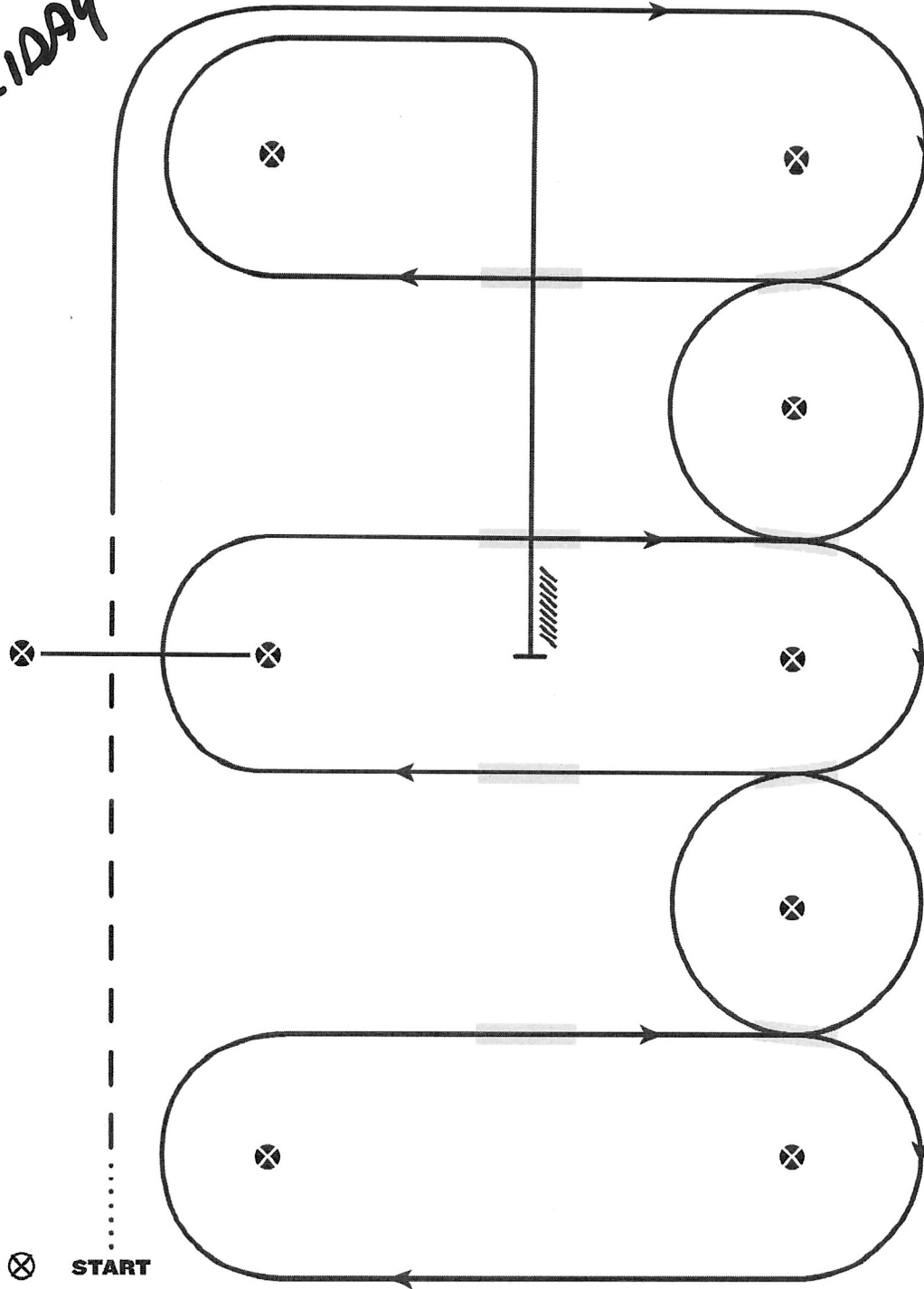

1. Walk at least 15 feet from start cone to the first marker, transition to jog, jog over log
2. Transition to the lope right lead & lope around end
3. First line change
4. Second line change
5. Third line change
6. Fourth line change lope around the end of arena
7. First crossing change
8. Second crossing change
9. Lope over log
10. Third crossing change
11. Fourth crossing change
12. Lope up the center, stop & back

REINING PATTERN 14

FRIDAY

ALL

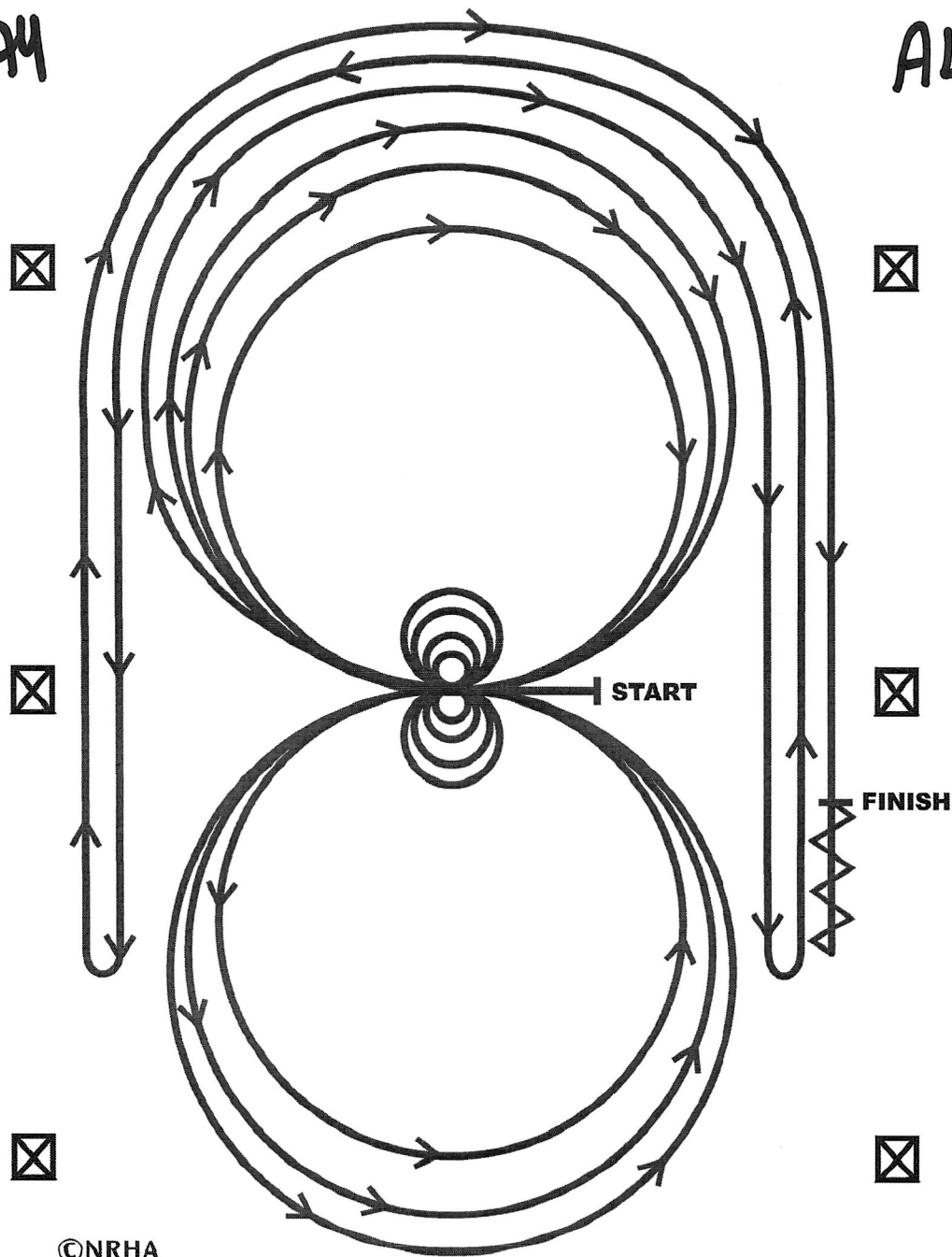

©NRHA

Horses may walk or jog to the center of arena. Horses must walk or stop prior to starting pattern. Beginning at the center of the arena facing the left wall or fence.

1. Complete four spins to the left. Hesitate.
2. Complete four spins to the right. Hesitate.
3. Beginning on the right lead, complete three circles to the right: the first two circles large and fast; the third circle small and slow. Change leads at the center of the arena.
4. Complete three circles to the left: the first two circles large and fast; the third circle small and slow. Change leads at the center of the arena.
5. Begin a large circle to the right but do not close this circle. Run up the right side of the arena past the center marker and do a left rollback at least twenty feet (six meters) from the wall or fence—no hesitation.
6. Continue back around previous circle but do not close this circle. Run up the left side of the arena past the center marker and do a right rollback at least twenty feet (six meters) from the wall or fence—no hesitation.
7. Continue back around previous circle but do not close this circle. Run up the right side of the arena past the center marker and do a sliding stop at least twenty feet (six meters) from the wall or fence. Back up at least ten feet (three meters). Hesitate to demonstrate the completion of the pattern.